



**XL Plastics**

Converting Machinery

### DELTA Series Servo Driven

- One Master Roll with Shaftless Unwinder and Driven Tension control system which is folded using a Vertical V Folding Device to form the pouch.
- Multiple sealing and cooling station.
- All Sealing stations actuated by individual servo motor system to Control Seal time.
- Multiple Nip Roller system along the web path to Maintain even tension on the film.
- Touch screen PLC for setting all parameters like Size, Speed, Dwell time, Temperature Recipe storage function on PLC to save all parameters of a particular Job for ease of operator.
- Pneumatic Retraction of all sealing station on stoppage of Machine.
- Servo motor actuated cutter assembly.
- Auto conveyor for batch collection of pouches.

DELTA Series Servo Driven

## Stand Up & Zipper

### Pouch Making Machine (Multi Servo)

- Stand-Up Pouch
- Zipper Pouch
- 3 Side Seal Pouch
- 3 Side Seal Multilayer Pouch

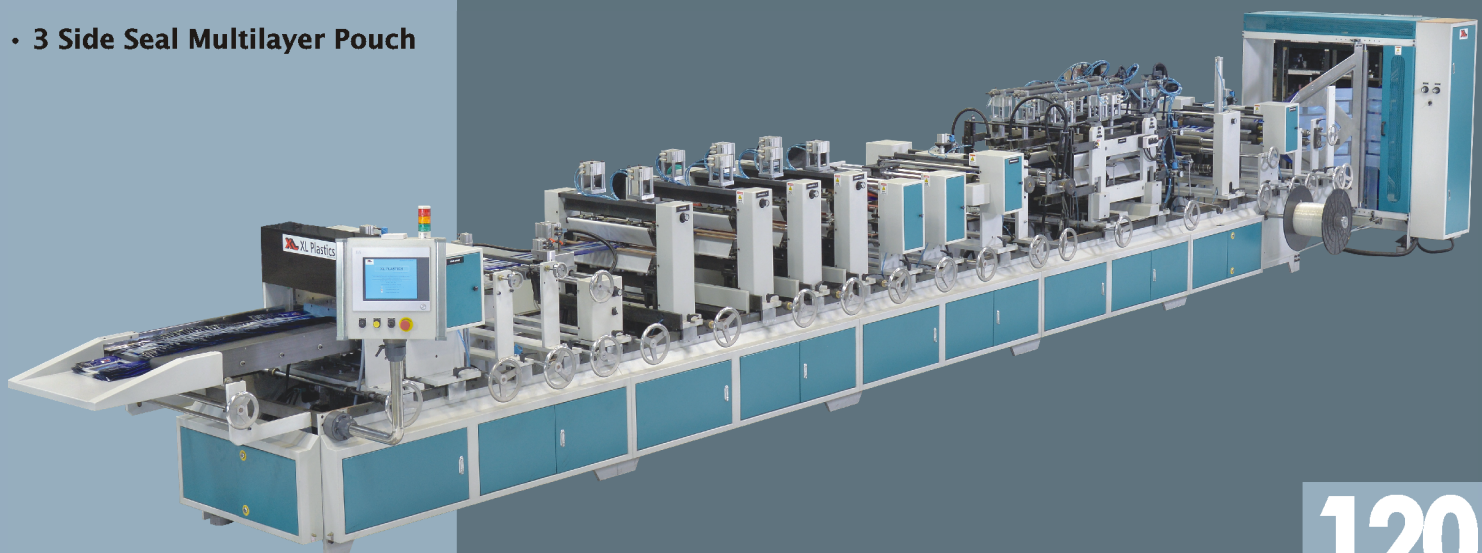

**120**  
Cycles / min.

Suitable for Film Compounds  
PE-PET / PE, PET / ALU / PE - PA / PE-PP / PP - Other combinations

**Model :**  
**SDP - 301-Z DELTA**  
**SDP - 501-Z DELTA**

Film flow  
←

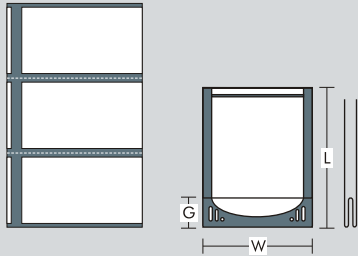

# Stand Up & Zipper Pouch Making Machine

## (Multi Servo System)

This is a versatile pouch making machine to produce 3 side seal, stand up with zipper Pouch & Doy pack.

The machine is equipped with One Master Shaftless unwinder to convert the film and make pouch from Single Web.

### Types of Pouches:

- 3 side seal pouches from master roll - Single up & Multiple ups.
- Stand up & zipper pouches 1 up from one Master Roll.

The machine is capable of making 3 side seal pouches from un laminated Co-ex multilayer film of PE/PA.

### Flow diagram of Stand Up & Zipper Pouch Making Machine

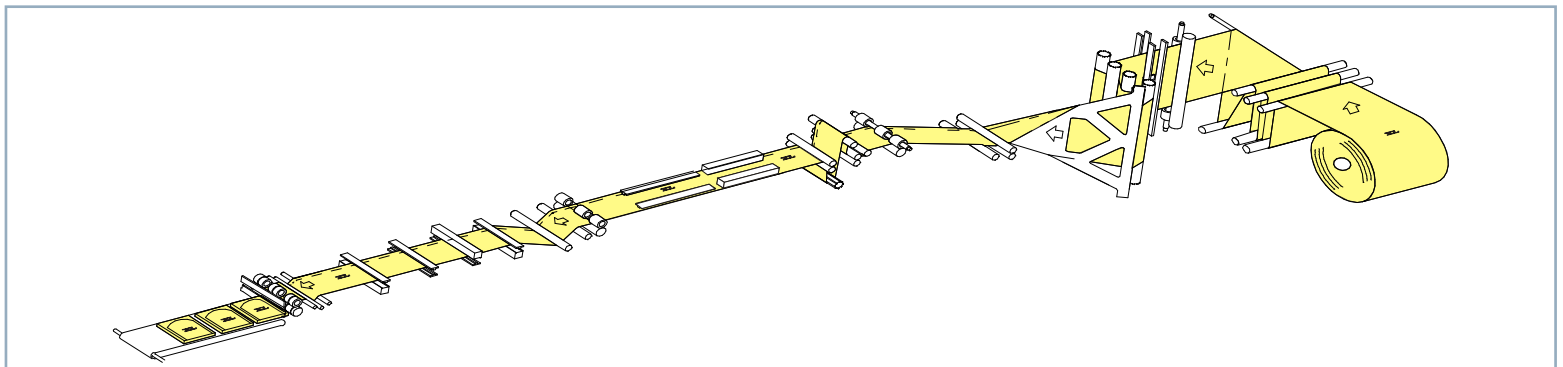

### Specifications For Stand Up & Zipper Pouch Making Machines

		<b>SDP - 501Z DELTA</b>		<b>SDP - 301Z DELTA</b>
Max Web Width Master Roll		1000 mm		700 mm
Max Gusset depth (G)		60 mm		60 mm
Pouch Size (mm)	Three Side Seal	W*	75 - 300	75 - 300
		L*	150 - 500	100 - 300
	Stand-up	W*	100 - 250	100 - 250
		L*	150 - 450	125 - 300
	Stand-up with zipper	W*	100 - 250	100 - 250
		L*	150 - 450	100 - 250
Max Speed	Three Side Seal	120 Cycles / Min		120 Cycles / Min
	Stand-up	120 Cycles / Min		120 Cycles / Min
	Stand-up with zipper	120 Cycles / Min		120 Cycles / Min
Compressed Air		250 L/Min @ 7 bar		250 L/Min @ 7 bar
Power		32 Kw - 415 V - 3 phase + neutral		27 Kw - 415 V - 3 phase + neutral

Standard Supply Voltage: 415 V, 3 Phase & Neutral, 50 Hz  
(Can be changed as per customers requirement)

The manufacturer reserves the right to change design/specifications because of continuous developments.

Accessories/Attachments shown on the photograph may not be part of the standard machine.

Max. Speed shown above is only indicative and the actual speed will depend on size, thickness and the materials of the film.

Compressed Air & Chilled Water, Not in our Scope of Supply.



## XL Plastics

Survey No.442-452, NH No. 8, Behind Galaxy Hotel, Por, Vadodara – 391 243.

Tel : + 91-265-2830176, 2830177, 2830178

E-mail : info@xlplastics.com

Website : www.xlplastics.com